

STP Test Plug

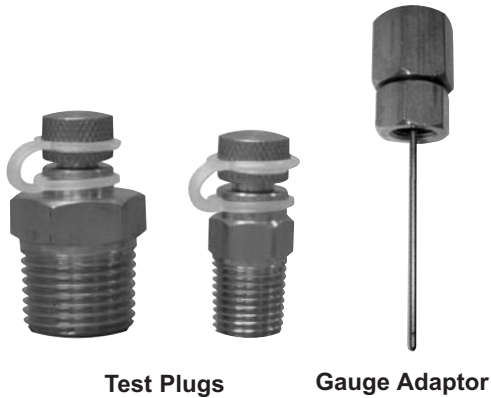

Test Plugs

Gauge Adaptor

Description & Features:

- Facilitates quick pressure and temperature readings at recommended test points within process
- Gauge adapters ship with protective aluminum sleeve
- 1 year warranty

Applications:

- Mainly used in heating, ventilation and air conditioning industries

Specifications

Material/Body	Brass
Diaphragm/Core	NBR (Buna N)
Temperature Rating	-40°F to 302°F (-40°C to 150°C)
Maximum Pressure Rating	1,000 psi (6895 kPa)
Connection	1/4" NPT or 1/2" NPT

0.25" Test Plug

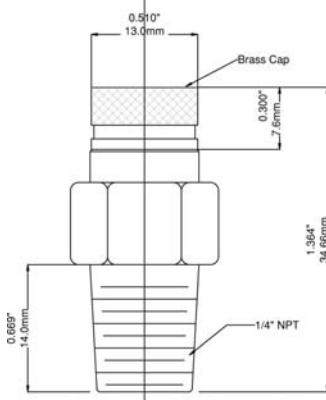

Order Codes (products in bold are normally in stock)

Brass Test Plug	
1/4" NPT Connection Male	STP001
1/2" NPT Connection Male	STP002

Gauge Adaptor	
2.75 OAL x 1.75" x 0.125" probe	STP003
2.25 OAL x 1.75" x 0.125" probe	STP004

Note: Other sizes and materials available upon request

0.5" Test Plug

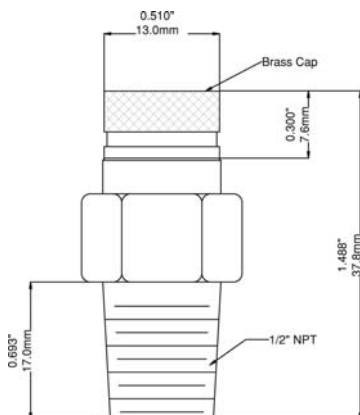

Gauge Adaptor 2.25"

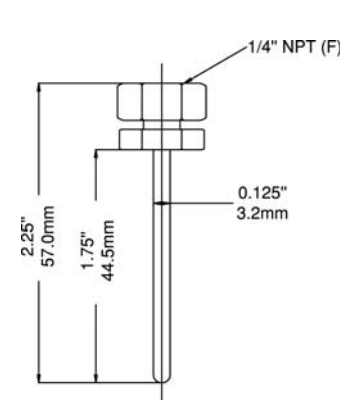

Gauge Adaptor 2.75"

